



**50Ω TERMINATED    3 GHz    SMA    N/O    S.P.4 T. SWITCH**

OPTIONS : INDICATOR / TTL DRIVE / SUPP.DIODES

**R F CHARACTERISTICS**

NUMBER OF WAYS : 4  
FREQUENCY RANGE : 0 - 3 GHz  
IMPEDANCE : 50 Ohms

FREQUENCY (GHz)	0 - 3
V.S.W.R <=	1.20
INSERT. LOSS <=	0.20 dB
ISOLATION >=	80 dB
AVER. POWER (*)	120 W

TERMINATION IMPEDANCE : 50 Ohms  
TERMINATION AVG. POWER AT 25°C : 1 W per termination  
3 W total power

**ELECTRICAL CHARACTERISTICS**

ACTUATOR : NORMALLY OPEN  
NOMINAL CURRENT AT 25°C (±10%) : 250 mA  
ACTUATOR VOLTAGE (Vcc) : 12V (10.2 to 13V) / NEGATIVE COMMON  
TERMINALS : solder pins (250°C max./30 sec.)  
INDICATOR RATING : 1 W / 30 V / 100 mA  
TTL INPUTS (E) - High level : 2.2 to 5.5V / 800µA at 5V  
- Low level : 0 to 0.8V / 20µA at 0.8V

**MECHANICAL CHARACTERISTICS**

CONNECTORS : SMA female per MIL-C 39012  
LIFE : 2.000.000 cycles per position  
SWITCHING TIME (nominal voltage;25°C) : < 15 ms  
CONSTRUCTION : splashproof  
WEIGHT : < 250 g

**ENVIRONMENTAL CHARACTERISTICS**

OPERATING TEMPERATURE RANGE (°C) : -40 , +85  
STORAGE TEMPERATURE RANGE (°C) : -55 , +85

(\* : average power at 25°C per RF path)

This information is given as an indication. In the continual goal to improve our products, we reserve the right to make any modifications judged necessary

**DRAWING**

General tolerance: ± 0,5 mm

**R574 312420**

Page  
2/2

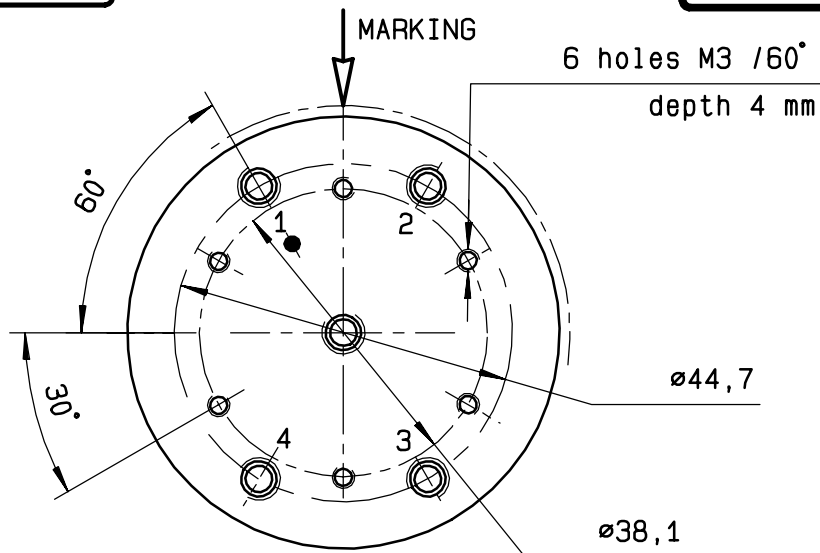

TTL input	RF continuity	Ind.
E1 = 1	IN ↔ 1	D.E
E2 = 1	IN ↔ 2	D.F
E3 = 1	IN ↔ 3	D.G
E4 = 1	IN ↔ 4	D.H

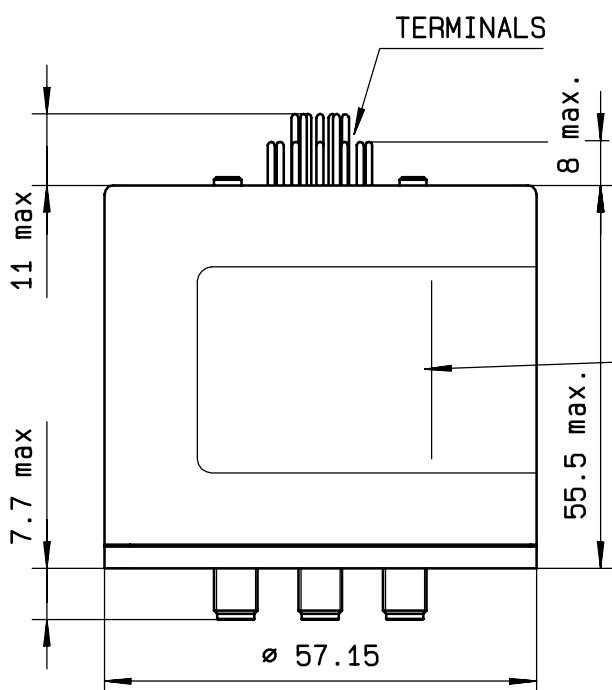

TOP VIEW (TERMINALS)

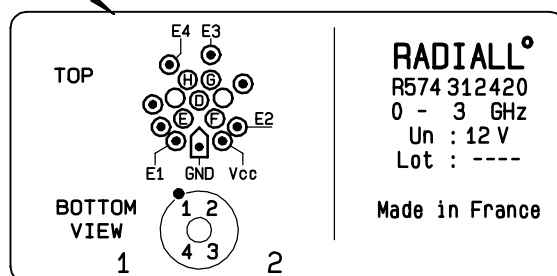

**SCHEMATIC DIAGRAM**

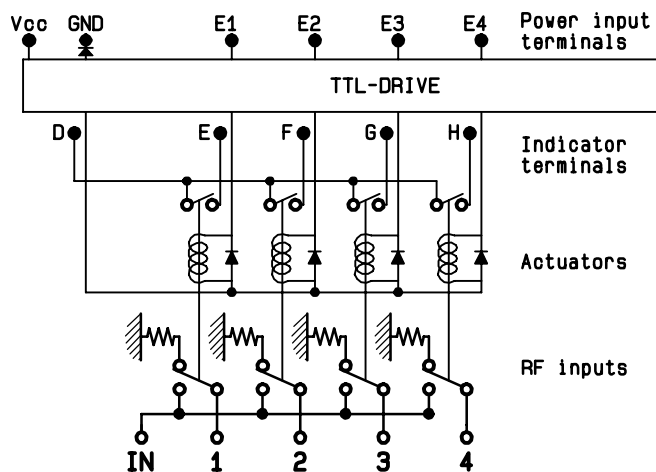

4113-9212 This information is given as an indication. In the continual goal to improve our products, we reserve the right to make any modifications judged necessary